

Design of a membrane facility for water potabilization and its application to Third World countries

J.M. Arnal Arnal*, M. Sancho Fernández, G. Martín Verdú, J. Lora García

*Chemical and Nuclear Engineering Department, Polytechnic University of Valencia, 46071 Valencia, Spain
Tel. +34 (96) 387-9633; Fax +34 (96) 387-7639; email: jarnala@iqn.upv.es*

Received 2 August 2000; accepted 16 August 2000

Abstract

The origin of this work is the necessity of guaranteeing water quality in underdeveloped countries where the population is supplied with water from rivers, lakes, etc. This water contains a certain number of viruses, bacteria and other microorganisms, which can cause some diseases. In these countries water disinfection methods are not usually applied or cannot be ensured an appropriate effectiveness. On many occasions water is used in the same condition as it is found at the source. This fact causes a high rate of infection that, although not grave in most cases, has been the origin of major epidemics in some circumstances. Membrane technology that allows disinfection on the basis of molecular size of particles is proposed as an option to the current system of treatment. Membrane processes carry out disinfection by means of size exclusion. At the end of the treatment, chlorination at low doses can be a way of keeping water in good condition for long periods of time. The aim of this work is design an ultrafiltration membrane treatment unit, with a spiral configuration, applicable to urban supply systems in underdeveloped countries, which cannot guarantee sufficient water disinfection. The proposed membrane module can be extended to N units, with a consequent increment of treated product, adapting the system to demand. An alternative for the design described has been considered. This option consists of a tubular module of manual operation. This facility intends to provide small communities that are geographically isolated from important urban centres with high-quality water.

Keywords: Membrane; Ultrafiltration; Potabilization; Disinfection; Third World countries; Manual plant

*Corresponding author.

Presented at the conference on Desalination Strategies in South Mediterranean Countries, Cooperation between Mediterranean Countries of Europe and the Southern Rim of the Mediterranean, sponsored by the European Desalination Society and Ecole Nationale d'Ingenieurs de Tunis, September 11–13, 2000, Jerba, Tunisia.

0011-9164/01/\$– See front matter © 2001 Elsevier Science B.V. All rights reserved

1. Introduction

This work is included in the project “Design and Construction of a Water Potabilization Membrane Facility and its Application to the Third World Countries” (AQUAPOT), developed by the research group of the Chemical and Nuclear Engineering Department of the Polytechnic University of Valencia, in answer to the request of the Cantonal Hospital of Paute (Ecuador). The project is being carried out in collaboration with the non-governmental organization, Association for the Cooperation with Ecuador (ACOEC), which is working on a project for sanitary aid and child education in Paute.

The project is based on the necessity of guaranteeing water quality in underdeveloped countries where the population is supplied with water from rivers, lakes, etc. This water contains a certain load of viruses, bacteria and other microorganisms, which cause some diseases.

The aim of the project, basically humanitarian, consists of providing hospitals and towns of the Third World with a reliable technology able to ensure the proper water quality for direct human consumption. On the other hand, the project means a great improvement in the control of public health and directly affects the sanitary conditions of the population from the point of view of diseases caused by ingestion of viruses and bacteria.

Some of the advantages of membrane techniques are simplicity and reliability, besides being very easy to extend plant capacity thanks to the modular characteristics of the membrane elements that constitute the treatment system.

The project consists of three different parts, which correspond to the following objectives:

- Design of a tubular ultrafiltration (UF) membrane manufacturing plant for obtaining 2-mm exterior diameter membranes.
- Design of a spiral-wound UF module with a throughput of approximately 1000 l/d of water

with purity similar to that of drinking water. This module will be installed at the Cantonal Hospital of Paute (Ecuador) where it will be checked in order to verify its performance. The hospital centre will act as the treated water distributor, supplying people with water for domestic use.

- Design of a manual tubular UF plant, which will be used at sites where there is not a water supply system.

This paper is focused on the aspects regarding the design of the treatment module and the manual performance plant.

2. Justification

Currently, excluding those caught up in war, about 250 to 300 million people a year are affected by disasters, and this figure is growing at a rate of around 10 million a year [1]. People affected by disasters have more probability of falling ill and dying because of diseases related to unsuitable conditions of sanitation and water supply than any other cause. The most important illnesses of this kind are diarrhoeic ones and others faecal-oral in nature. Unsuitable sanitation, poor hygiene and contaminated water favour their transmission. The main purposes of emergency programmes related to water supply and sanitation are to provide the minimum necessary amount of water and reduce the faecal-oral transmission of illnesses.

One of the main problems related to natural disasters concerns the response time of international organizations with regard to delivering of water treatment material. Generally, response time until the first potabilization plant is delivered is around 10 days, too long considering the important role of water in our lives. In Table 1, some examples of the time elapsed before delivering potabilization plants in some of the most recent natural disasters are shown.

Table 1
Response time in some natural disasters

Disaster (date)	Affected people	Days elapsed until delivery of potabilization plants
Floods in Venezuela (March 2000)	600,000	6
Floods in Mozambique (May 2000)	2,000,000	15

Until international aid arrives, national organizations are in charge of immediate help, but these organizations, due to the own infrastructure of the countries where natural disasters are likely to occur, do not usually have the necessary facilities and equipment for water treatment. On the other hand, potabilization plants supplied work with petrol or diesel oil and they are considerably larger.

The projected manual performance plant has some advantages such as not requiring any fuel or additional power source, facilitating its application, and a compact design to allow for easy handling and transport. Furthermore, this will allow the storage of facilities with these characteristics in the emergency stores of national organizations in any country where natural disasters occur, reducing the response time for the affected population supply with safe water.

3. Definition of the problem

In some cultures, particularly in underdeveloped countries, water disinfection methods are not usually applied and, in case they are, they cannot guarantee effectiveness. Currently, the most used disinfection method in these countries consists of boiling water, with a consequent waste of energy and limitation of good-quality water imposed by the system. Due to these factors, on many occasions thermal treatment is not applied, and the water is used in the same condition as it is found at the source. This causes

a high rate of infections that, although they are not grave in most cases, have been the origin of major epidemics in some instances.

The main risks associated with water are related to biological sources. There are about two dozen infectious diseases whose gravity depends on water quality. These illnesses can be caused by viruses, bacteria, protozoa or larvae. Other microorganisms present in water are fungi, algae, rotifers and crustaceans.

Viruses are tiny infectious agents (pathogens) which are steady in the environment and are generally transferred in water. They are particles composed of a protein cover that surrounds a nucleic acid centre. Virus sizes range from 10 to 25 nm. Hepatitis A is an example of a viral disease that can be developed from contaminated water. Bacteria are unicellular organisms that live in the soluble food of water. They are the most basic units of vegetal life and their sizes vary from 0.5 to 5 μm . Some of them form resistant spores that can remain inactive under some environmental conditions but become active when conditions change. Protozoa are also unicellular organisms without a cellular wall; they are colourless and generally mobile. Some of them are pathogens and remain in drinking water. They are able to form spores or cysts highly resistant to usual disinfection methods. Fortunately, these organisms can be removed by means of two simple processes: filtration and disinfection.

Table 2 shows the relative sizes of some of the smallest microorganisms [2].

Table 2
Relative size of some microorganisms

Microorganism	Size (μm)
Protozoa:	
<i>Giardia lamblia</i>	$5\text{--}15 \times 10^{-20}$
Ovoid cyst	6×10
<i>Entamoeba histolytica</i>	15×25
Cyst	10×15
Yeast, fungi	1–10
Bacteria (<i>Salmonella</i> , <i>Shigella</i> , <i>Legionella</i> , etc.):	
Spherical (cocci)	0.5–4
Rod-shaped (bacilli)	$0.3\text{--}1.5 \times 1^{-10}$
<i>Escherichia coli</i> (human feces)	0.5×2
Rod-shaped, curved (vibrios)	$0.4\text{--}2 \times 1^{-10}$
Spiral-shaped (spirilla)	< 50 in length
Filamentous	> 100 in length
Viruses: Hepatitis A	0.01–0.025
Proteins ($10^4\text{--}10^6$ dalton)	0.002–0.1
Enzymes	0.002–0.005
Antibiotics, polypeptides	0.0006–0.0012

4. Water treatment

4.1. Conventional treatment

The production of safe water with regard to illnesses requires processes such as chemical precipitation, adsorption, sedimentation and filtration for removing biological species, colourings, tastes, odours, iron, silicates and manganese. Taste has no direct repercussions on health, but if the supplied water has a bad taste, consumers may drink water from unsafe sources, endangering their health.

The minimum treatment for drinking water production is direct filtration through molecular sieves, but coagulation, sedimentation and filtration are the most commonly applied operating units in drinking water production.

4.2. Membranes techniques (ultrafiltration)

Membrane separation, as well as active carbon adsorption, are well-known technologies,

able to achieve low levels of organic matter and the reduction of particulate rates demanded by the electronics industry or for municipal drinking water. UF has many advantages in comparison with conventional clarification and disinfection operations. Some of them are:

- It does not need chemical agents (coagulants, flocculants, disinfectants, etc.)
- Separation takes place by means of size exclusion
- Constant production of good-quality treated water irrespective of feed wastewater quality
- Compact plant and process
- Simple automation

Table 3 shows the comparison of UF and other water treatment processes [2].

As a consequence of all these advantages, UF can enter the water purification field, which has been dominated by chemical coagulation and deep filtration techniques. Since the late 1980s, UF applications in water treatment have increased, and currently a great number of UF plants are in operation for water disinfection.

UF does not retain low-molecular-weight substances dissolved in water. It only retains macromolecules or high-molecular-weight substances and colloidal and suspended substances. The three main characteristics that define a UF membrane are the cut-off, the selective layer material and permeate flow ($\text{l/m}^2\text{h}$) [3].

The cut-off is the maximum molecular weight of a dissolved or suspended particle in water to go through the membrane. It is an average value, which represents pore size distribution on the selective layer of the membrane. Ultrafiltration membrane cut-off ranges between 0.002 and $0.2 \mu\text{m}$.

Separation in the UF technique takes place on the basis of particle size. Those particles with a greater size than the cut-off are retained by the membrane and flow with the retentate stream. The transport process is based on a capillary

Table 3
Ultrafiltration compared with some water treatment processes

Contaminant category	Coagulation, sedimentation, filtration	Lime softening	Reverse osmosis	Ultrafiltration	Chemical oxidation, disinfection
Total coliforms	G-E	G-E	E	E	E
<i>Giardia lamblia</i>	G	G	E	E	G
Viruses	G-E	G-E	E	E	E
<i>Legionella</i>	G-E	G-E	E	E	E
Turbidity	E	G	E	E	P
Organics:					
VOCs	P	P-F	F-G	P	P-G
SOCs	P-G	P-F	F-E	P	P-G
Pesticides	P-G	P-F	F-E	P	P-G
THMs	P	P	F-G	P	P
THM precursors	F-G	F-G	G-E	P-F	P
Colour	F-G	F-G	G-E	F	F-E
Iron	F-E	E	G-E	G	G-E
Manganese	F-E	E	G-E	G	F-E
Taste and odour	P-F	P-F	—	—	F-E

P: poor (0–20% removal); F: fair (20–60% removal); G: good (60–90% removal); E: excellent (90–100% removal); —, insufficient data

transference mechanism, which considers membranes constituted by lots of capillary pores, so selectivity and permeability are determined by pore diameter, number of pores and the pore distribution curve.

Membrane UF technology carries out disinfection by means of size exclusion without heating. At the end of the treatment, chlorination at low doses can be a way of keeping good quality water for long periods of time.

5. Plant description

5.1. Design

The projected membrane module can be applied to urban supply systems of those underdeveloped countries that cannot guarantee accurate water disinfection. The proposed mem-

brane module, with a treatment capacity of 1000l/d, can be extended to N units, with a consequent increase in the treated product, adapting the system to demand.

The designed module will allow the application of membrane technology in towns or sites which have a “drinking” water supply system and, on the basis of demand, needs will be met by means of installing N modular units. The connection of these units (series or parallel) will be defined by feed stream characteristics and desired final product quality.

The extent of the project, conceived under a humanitarian philosophy of protection against infections caused by the drinking of contaminated water, has limitations regarded its application at sites which, in some cases, do not even have elementary services, e.g., water or electrical supply systems. For this reason it has

been projected as a variant of the previous design. This modification is equipped with the module described above, but in this case the facility uses manual performance. It is intended to supply small communities (30–40 people) who are geographically isolated from important urban centres with treated waste. The application of this module will allow the direct use of the water source with proper health guarantees.

It is important to bear in mind during the design of the plant the fact that its operation has to be simple so it can be used for anyone to “manufacture” the amount of water needed by a community.

This facility will allow the production of approximately 1000l/d of treated water. This throughput can provide water for direct consumption for 300 people per day, working at top efficiency. If there is a population increase, the extension of the plant capacity can be easily done, adding more facilities, adapting production to demand.

On the other hand, if evolution of the area occurs, the facility can be modified and adapted to the new conditions. For instance, if the town is provided with an electrical supply system, it will allow the replacement of the manual steering wheel by an electrical engine. Furthermore, a provision of water piping with a pressure higher than 3 kg/cm^2 will allow the substitution of all the pumping equipment, keeping only the membrane module.

Fig. 1 shows the manual facility with the UF module. The vessels to be filled with treated water will be placed at the low part of the plant on a support. These vessels have to be hygienic and suitable for the needs and local customs with regard to size, shape and structure.

The performance of the plant is the following: the rotary movement of the steering wheel (1) sets the pump (2) in motion. The pump leads the water to the module (3) where, by means of the pipe (4), the feed water is divided into two

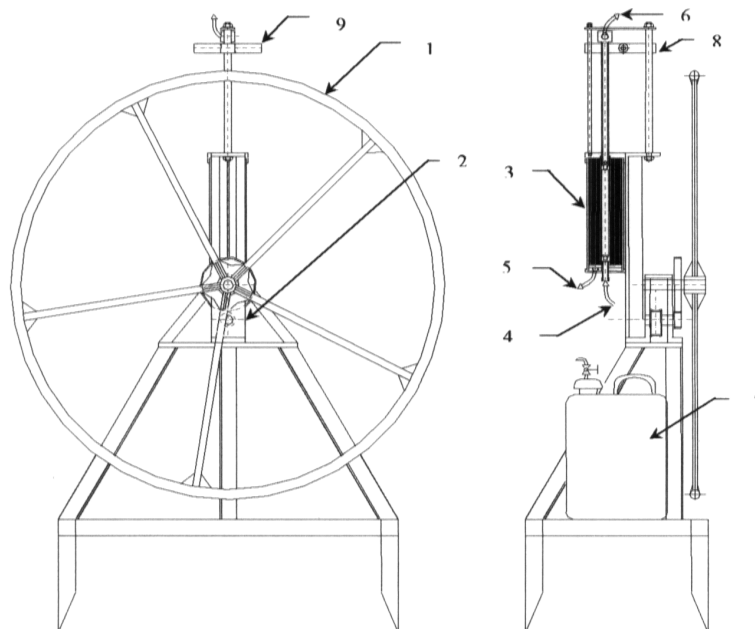

Fig. 1. Manual ultrafiltration plant.

streams: the permeate (5) and the concentrate (6). The permeate (treated water) is stored in a vessel (7). The pumping continues until the desired amount of water is stored. The concentrate can be chlorinated to remove microorganisms and then discharged to the environment or reused in the sanitary system.

5.2. Module cleaning

During facility performance microorganisms are accumulated inside the module and they may cause membrane damage. If the microorganisms keep in contact with the membrane long enough, they can proliferate, being able to cause the phenomena of “bioflow”, which is the generation of channels by microorganisms. This phenomenon can make the membrane useless.

In order to avoid bacterial growth and microorganism accumulation, the module has to be cleaned periodically. The process of cleaning is the following: with the pump turned on, the axis (8) is moved from top to bottom. This process is repeated between 10 and 20 times. After having finished the cleaning, the module is emptied out and germicide is added.

5.3. Germicide formulation

The germicide plays an important role in the module conservation and guarantees proper performance for its life time. About two droplets of commercial bleach are added to 10l of treated water. After being stirred, the mixture is ready to be used as the disinfectant of the module.

Acknowledgements

We wish to express our appreciation to ACOEC, the Cantonal Hospital of Paute and the Red Cross of Valencia for all their help with the development of this project.

References

- [1] World Disasters Report, International Federation of Red Cross and Red Crescent Societies, 2000.
- [2] American Water Works Association Research Foundation, Water Treatment Membrane Processes, McGraw-Hill, New York, 1998.
- [3] H. Barnier and A. Maurel, Clefs CEA, 29 (1994) 14.